

CONCRETE JACKING PIPES

Bilcon Industries stands as a prominent manufacturer of precast concrete items in Singapore and Malaysia. Since 1963, we have consistently delivered high quality concrete products to fulfil the growing demand for infrastructure precast units. As early as the 1970s, Bilcon Industries established itself as a specialist in manufacturing spun reinforced concrete pipes, solidifying its reputation in the industry.

In our journey of growth, innovation remains a constant. Throughout the years, we have dedicated extensive efforts to enhance the production processes of high-quality jacking pipes designed for trenchless tunnelling. Our high strength jacking pipes are currently the preferred system among top contractors in Singapore. Bilcon Industries is actively collaborating with reputed technology firms such as Schlüsselbauer Technology to elevate productivity through automation and introduce cutting-edge precast civil products to the local market.

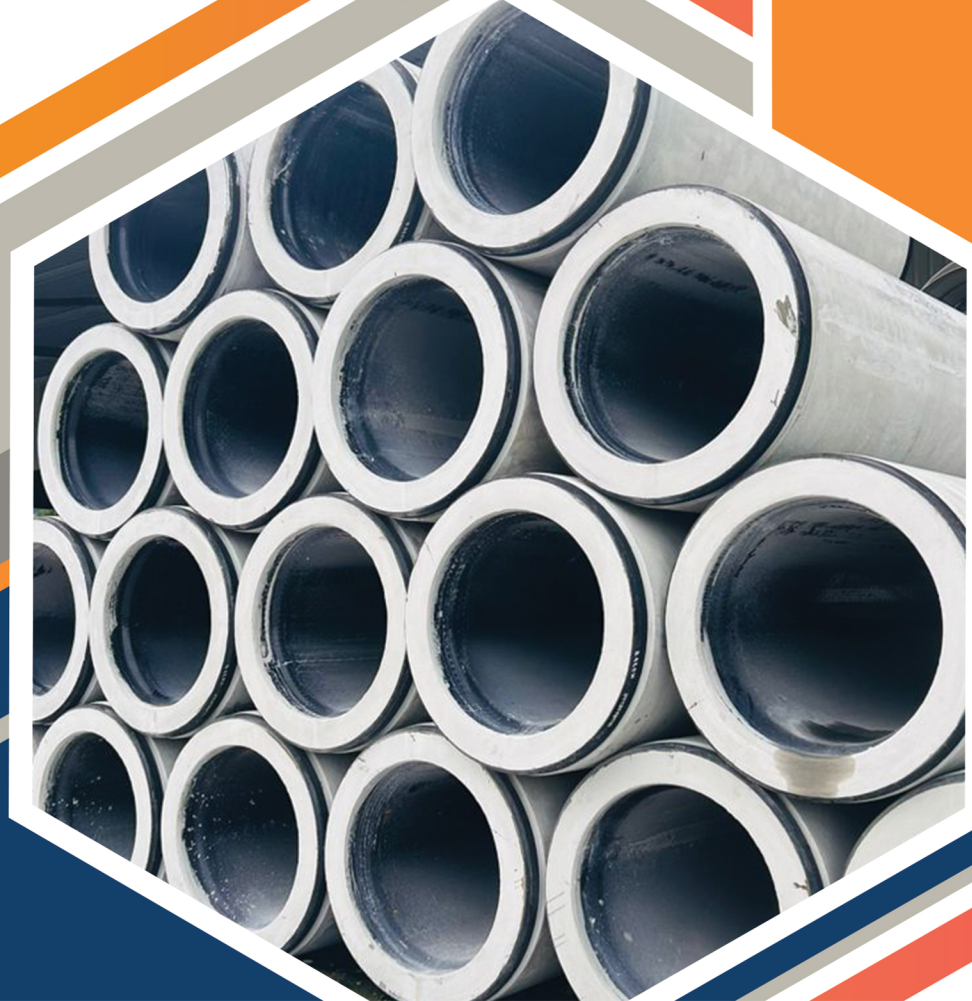

BILCON AUSTRALIA CONCRETE JACKING PIPE TECHNICAL INFORMATION

Internal Dia. (mm)	External Dia. (mm)	Wall Thickness (mm)	Effective Length (mm)	Packer Thickness (mm)	Steel Collar Thickness (mm)	Weight (kg)	Max Jacking Load ² (tonnes)	Collar Type
300	450	75	2000	12	2	430	75	F
400	650	125	2000	12	2	990	204	F
450	650	100	2000	12	2	830	210	F
500	675	87.5	2000	12	2	775	147	F
500	730	115	2000	12	2	1,070	170	F
600	775	87.5	2000	12	2	910	173	F
600	875	137.5	2000	12	2	1,530	270	F
700	875	87.5	2000	12	2	1,040	199	F
700	960	130	2000	12	2	1,630	350	F
800	960	80	2000	12	4	1,062	210	F
800	1052	126	2000	12	4	1,760	462	F
900	1140	120	2000 ¹	18	4	1,850	481	F / B
1000	1250	125	2000 ¹	18	4	2,125	558	F / B
1050	1300	125	2000 ¹	18	4	2,220	583	F / B
1200	1470	135	2000 ¹	18	4	2,720	727	F / B
1350	1600	125	2000 ¹	18	6	2,780	734	B
1500	1780	140	2000 ¹	18	6	3,470	935	B
1650	1950	150	2000 ¹	18	6	4,080	1,113	B
1800	2170	185	2000 ¹	18	6	5,540	1,559	B
2000	2410	205	2900	18	8	9,890	1,944	B
2100	2470	185	2900	18	8	9,245	1,797	B
2400	2810	205	2900	18	10	11,680	2,300	B
2500	3000	250	2900	18	10	15,035	3,020	B
3000	3500	250	2900	18	10	17,770	3,573	B

CONCRETE JACKING PIPE RANGE

Standard:
AS/NZS 4058:2007 Precast concrete pipes
(pressure and non-pressure)

BILCON AUSTRALIA CONCRETE JACKING PIPE TECHNICAL INFORMATION

1. Also available in effective lengths of 2900mm
2. Max Jacking Loads calculated in accordance with BS EN 1916:2002 Annex B, with total safety factor of 3.33

DRAWINGS

Typical B-Series Detail

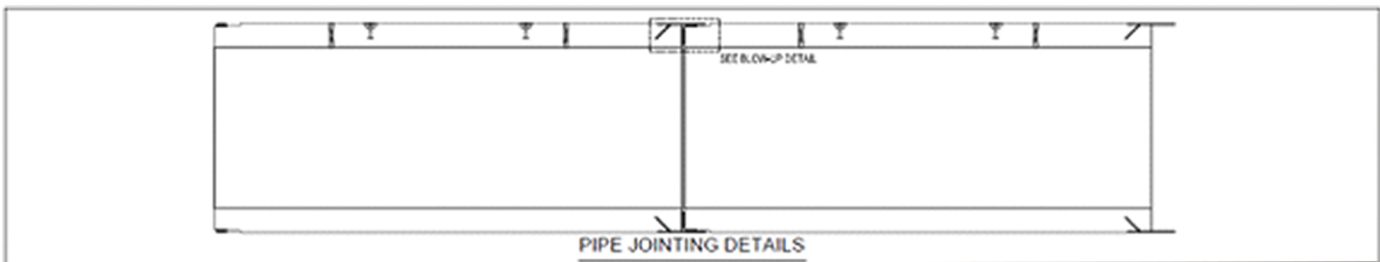

BLOW-UP DETAIL

JACKING PIPE ACCESSORIES

RUBBER RING DETAILS		
B	g	e
(mm)	(mm)	(mm)
72	10	19

CHIPBOARD PACKING		
ID	OD	THK
(mm)	(mm)	(mm)
1840	2100	18

Typical F-Series Detail

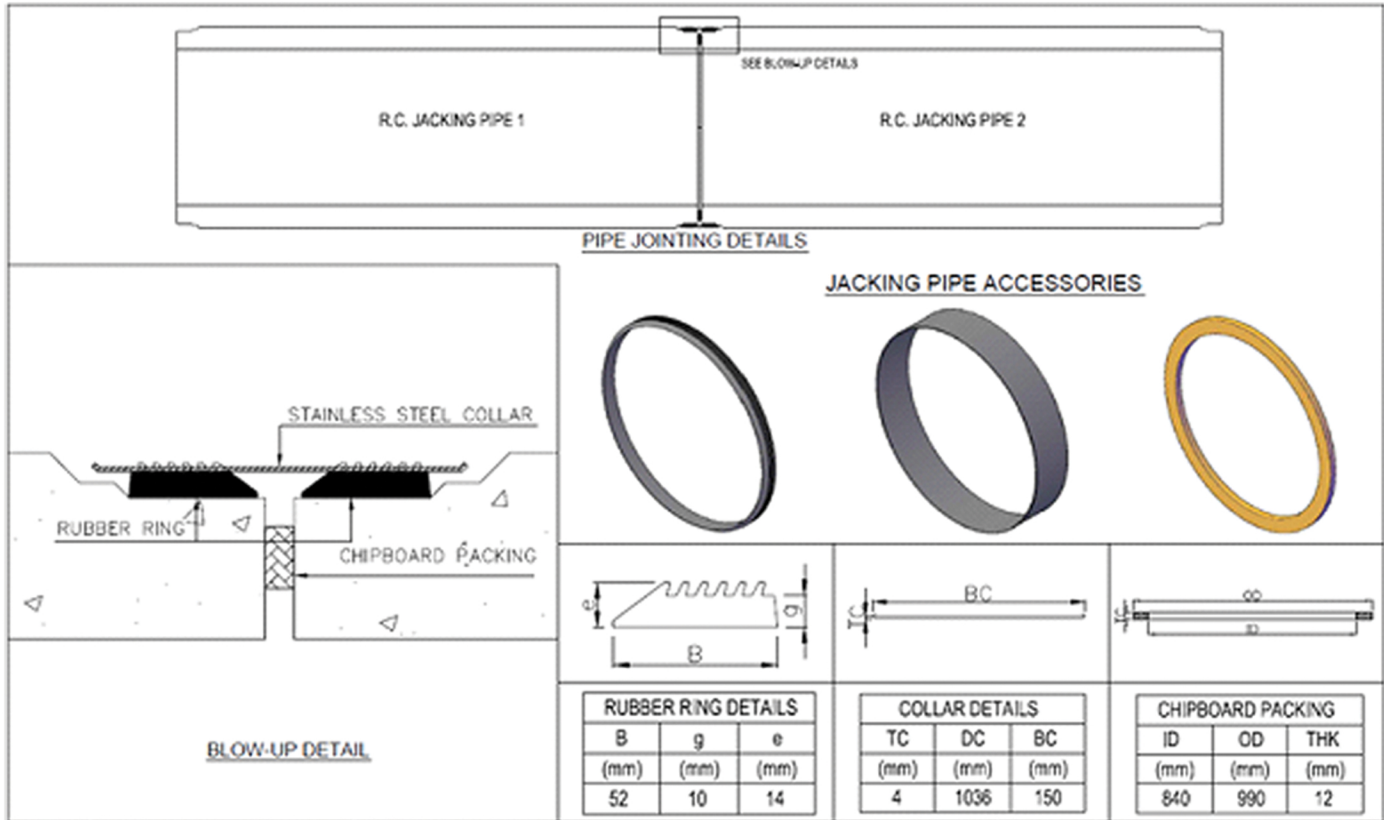

Typical Pipe Properties

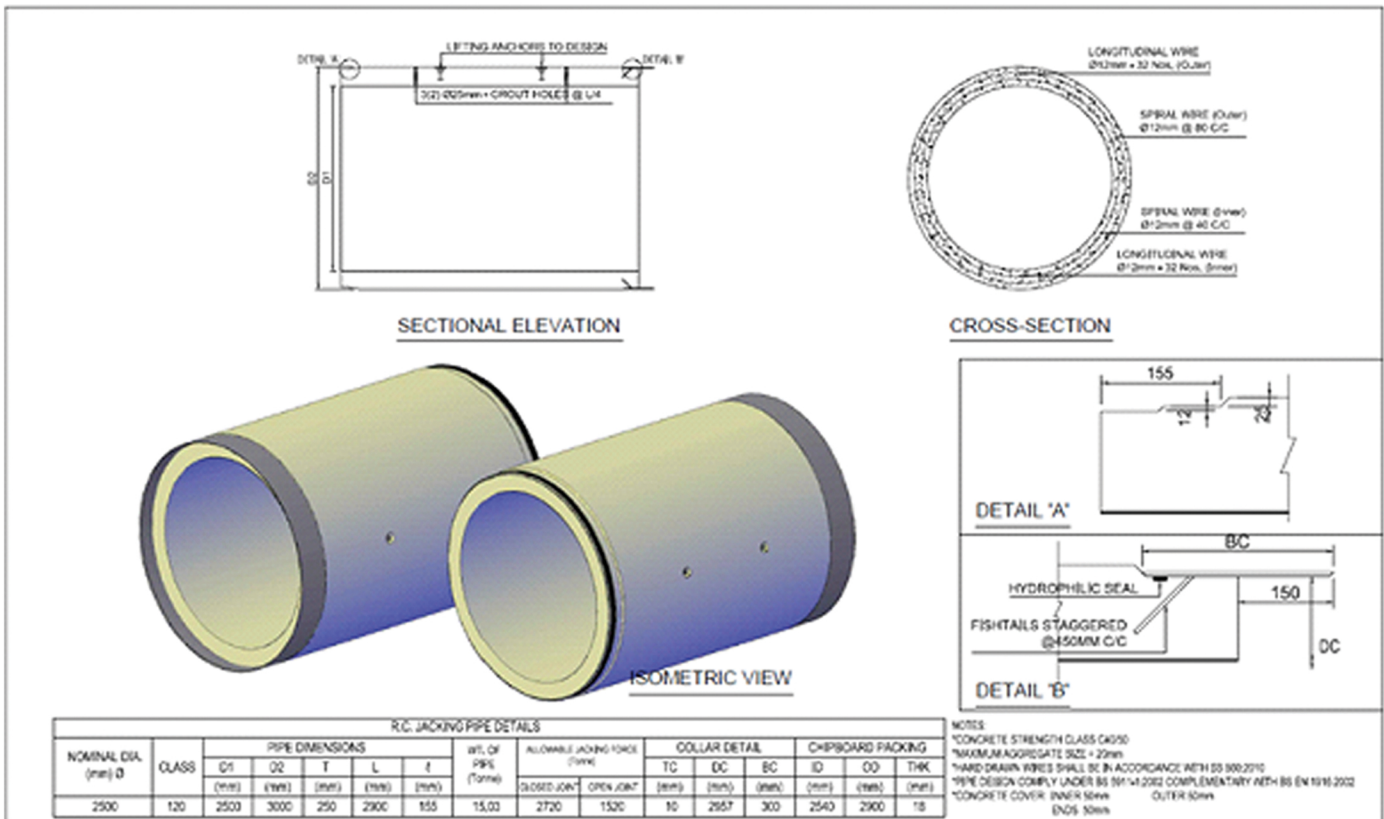

Typical Pipe Jointing

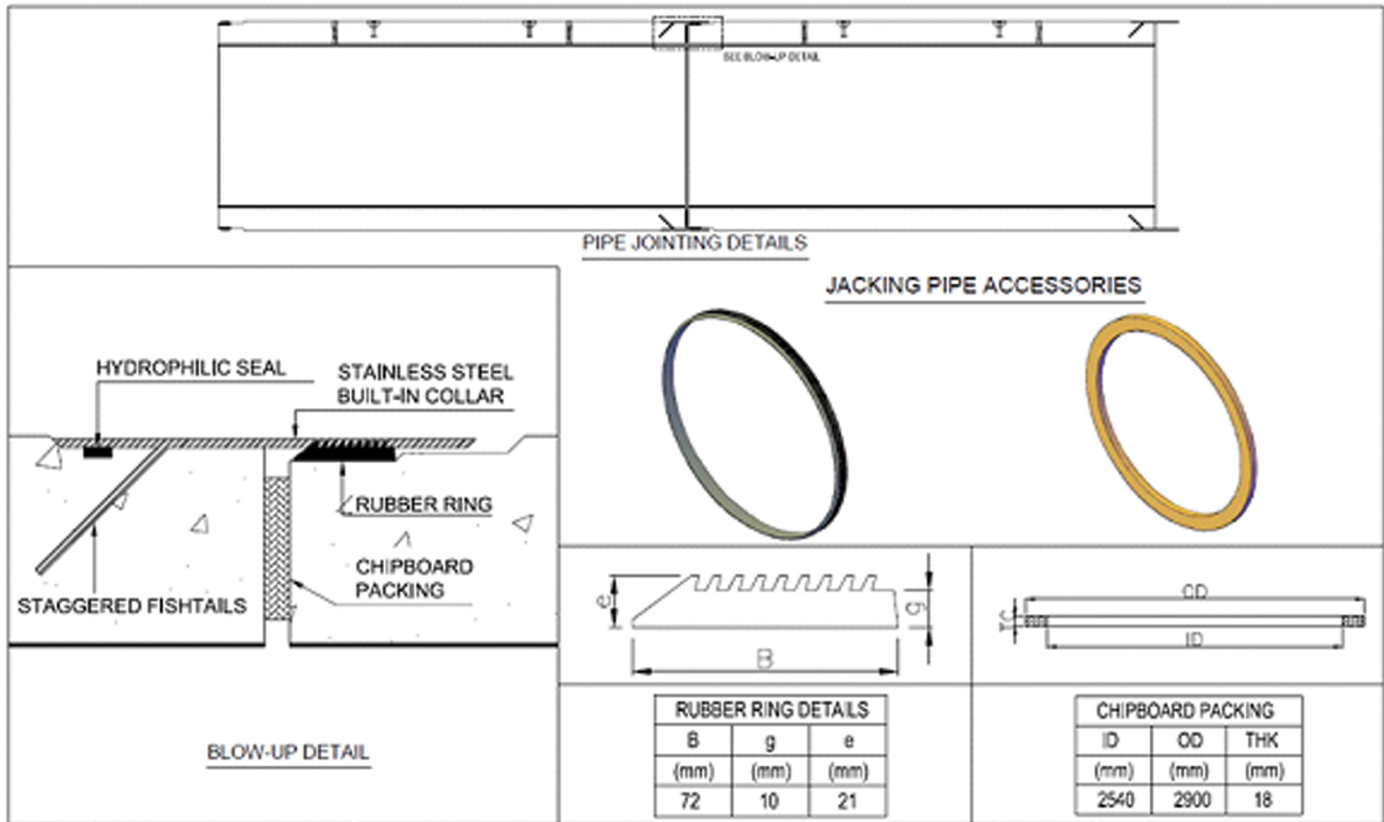

Typical Inter Jacking Pipe – Intermediate 1 - Details

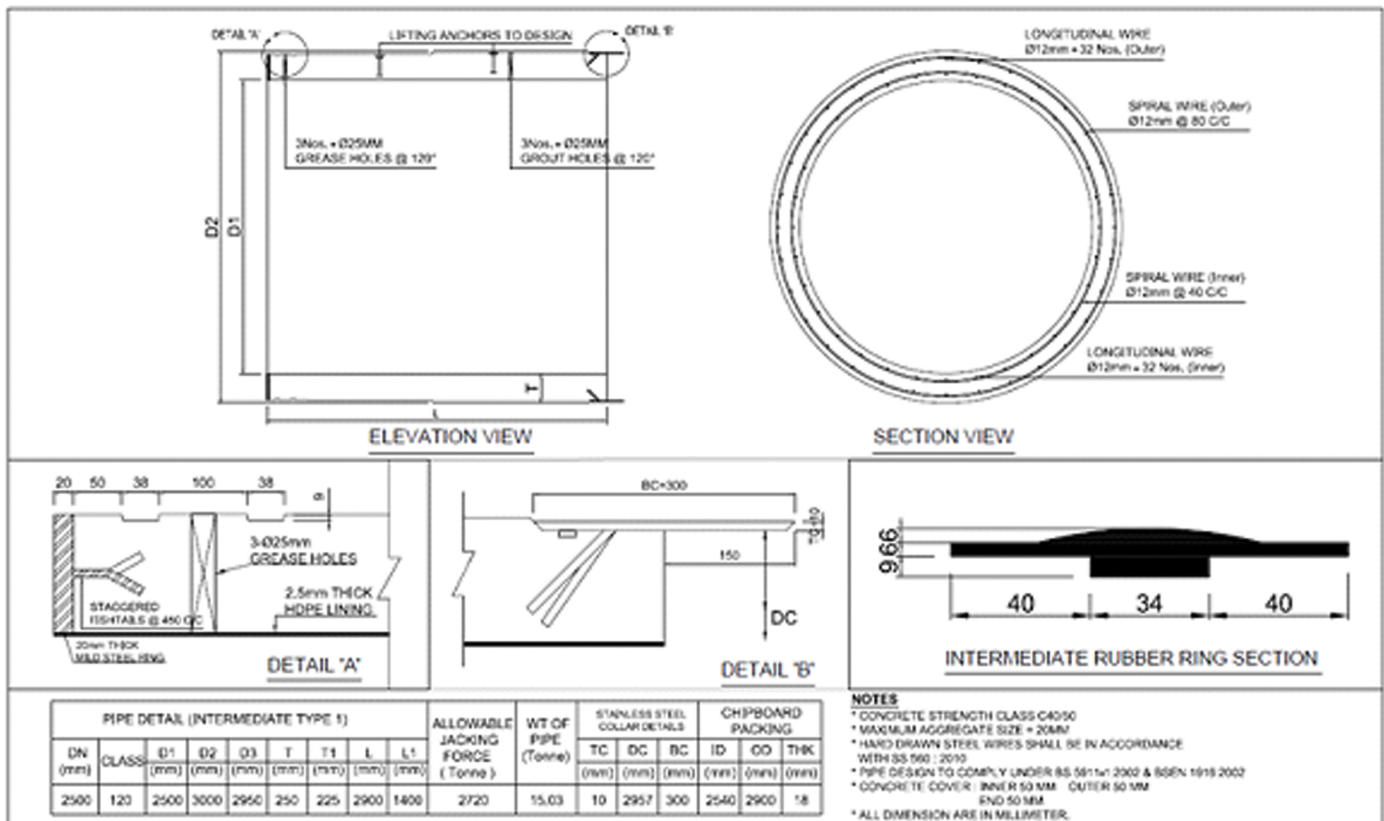

Typical Inter Jacking Pipe – Intermediate 2 – Details

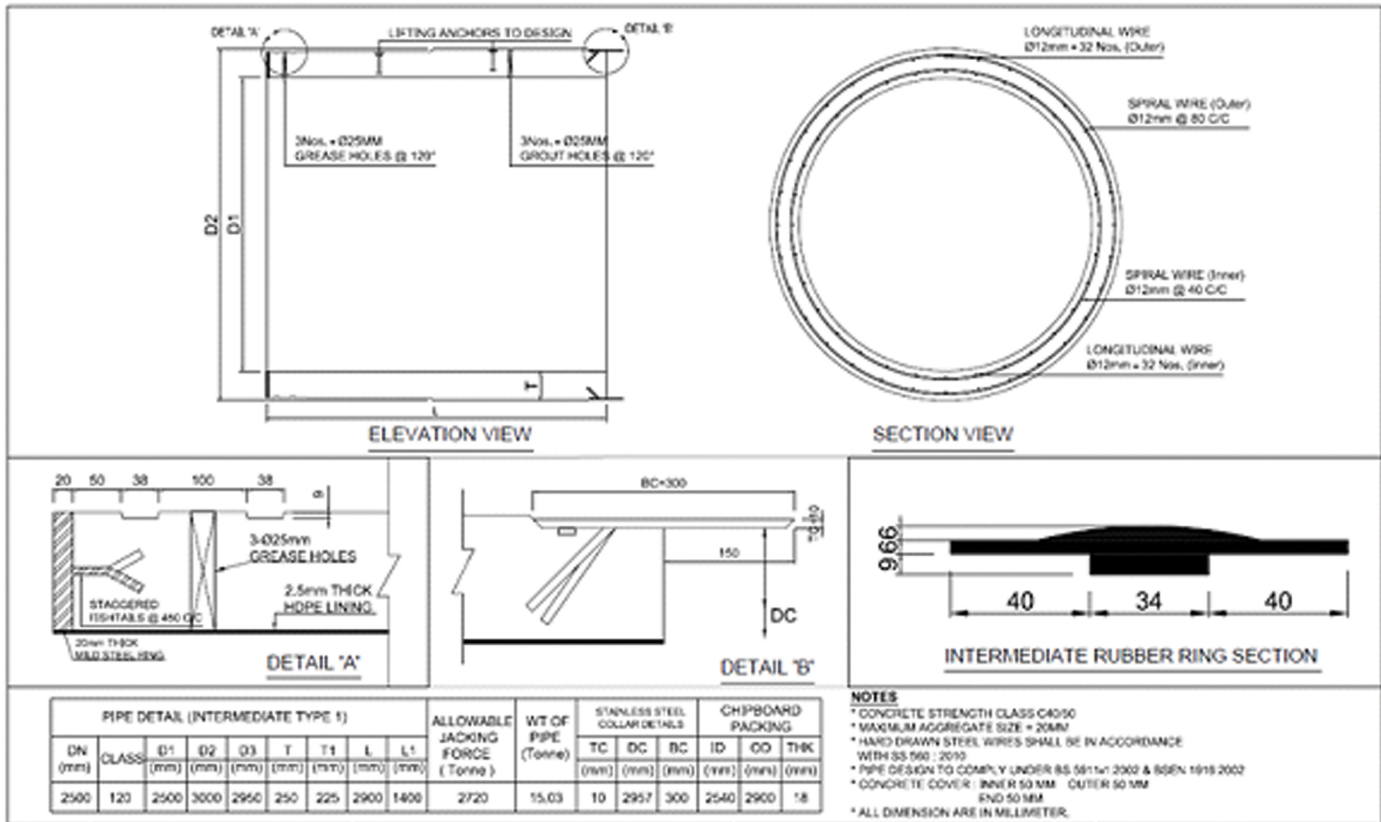

Typical Inter Jacking Pipe – Assembly – Details

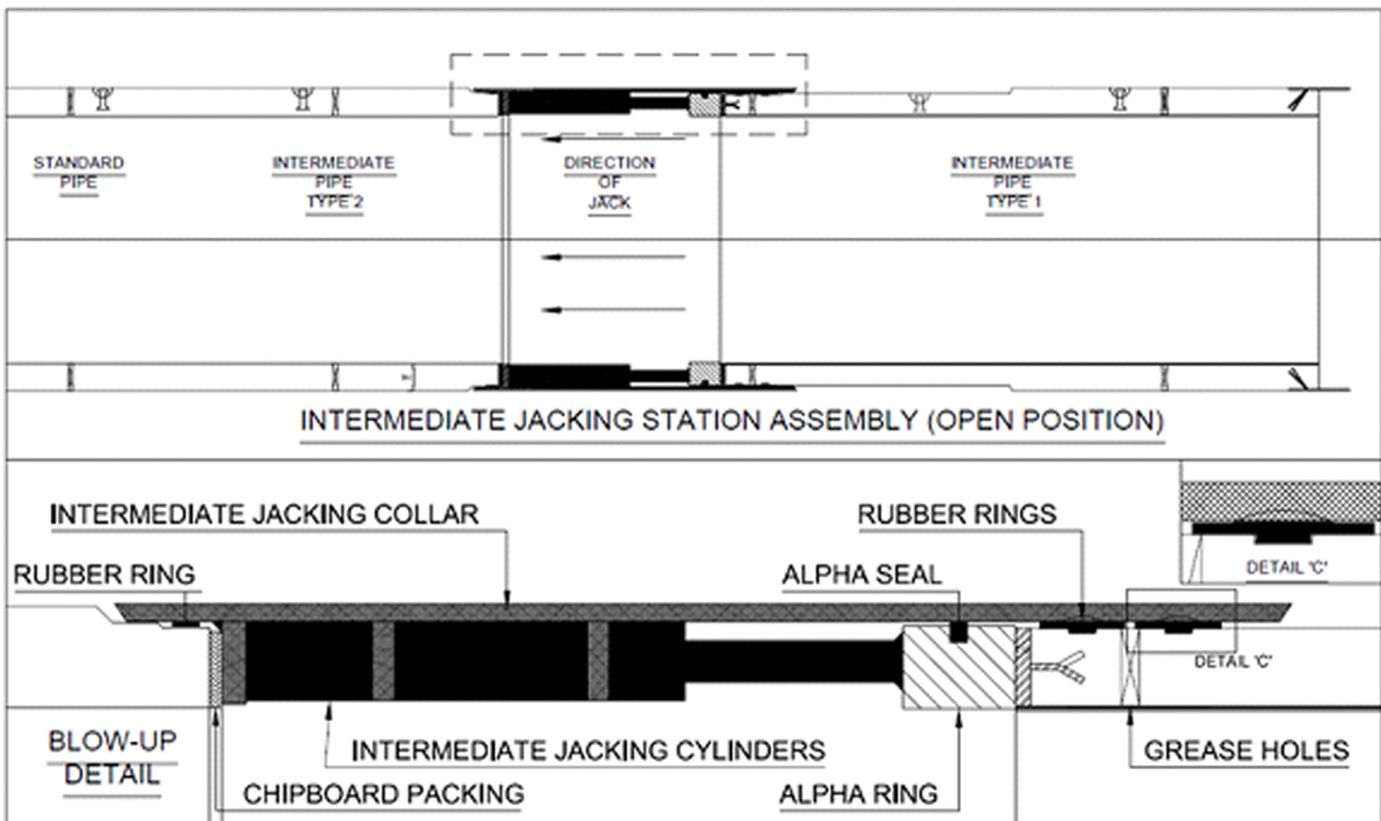

BILCON

AUSTRALIA



BILCON

AUSTRALIA



+61414009334



info@bilcon.com.au

For further information please visit <http://www.BILCON.COM.AU>